

THIS DRAWING IS UNPUBLISHED. RELEASED FOR PUBLICATION
 BY TYCO ELECTRONICS CORPORATION ALL RIGHTS RESERVED.

LOC		DIST		REVISIONS			
P	LTR	DESCRIPTION	DATE	DN	APD		
L		REV PER OS1D-0134-00	27FEB01	MM	JR		

27FEB01 JR

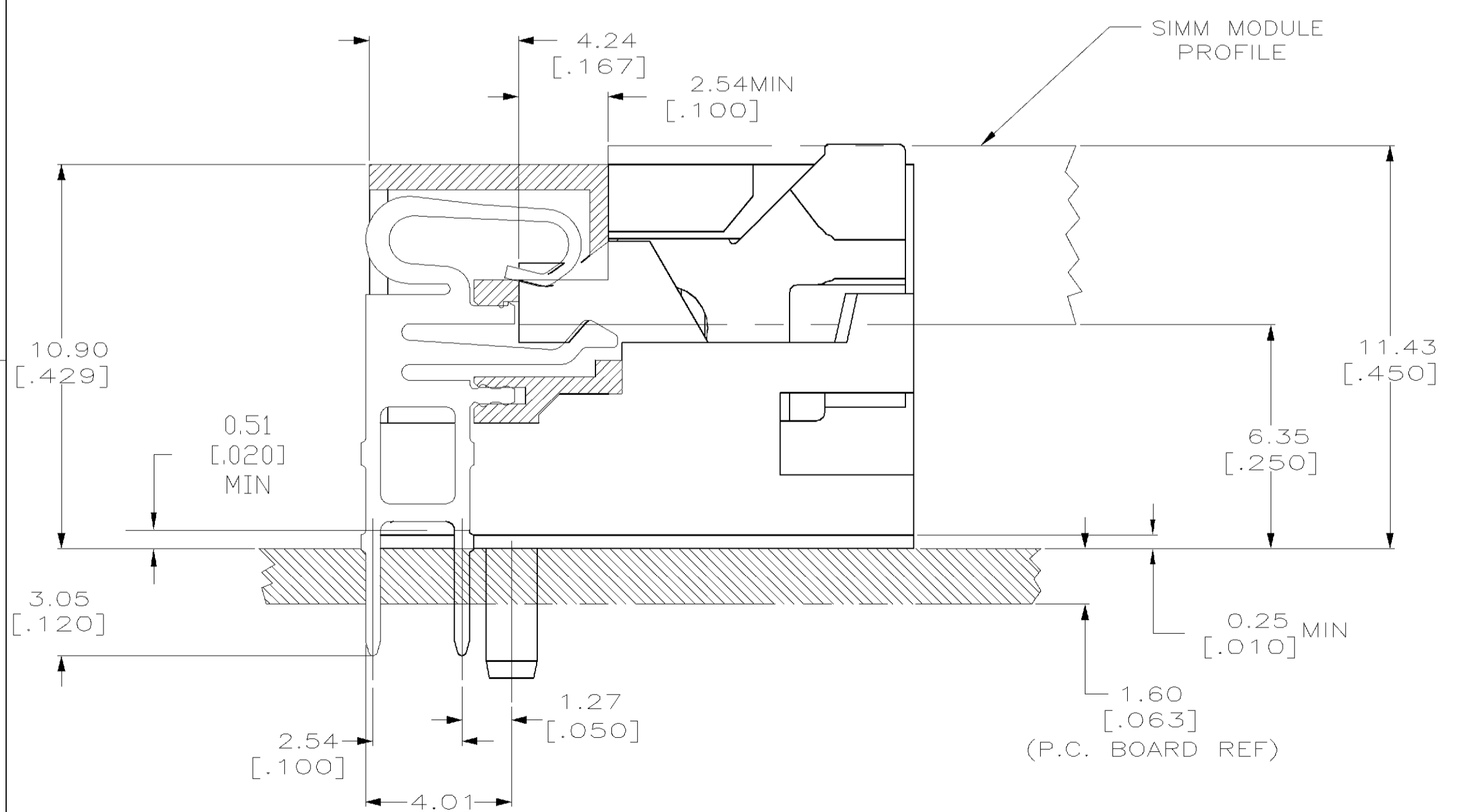
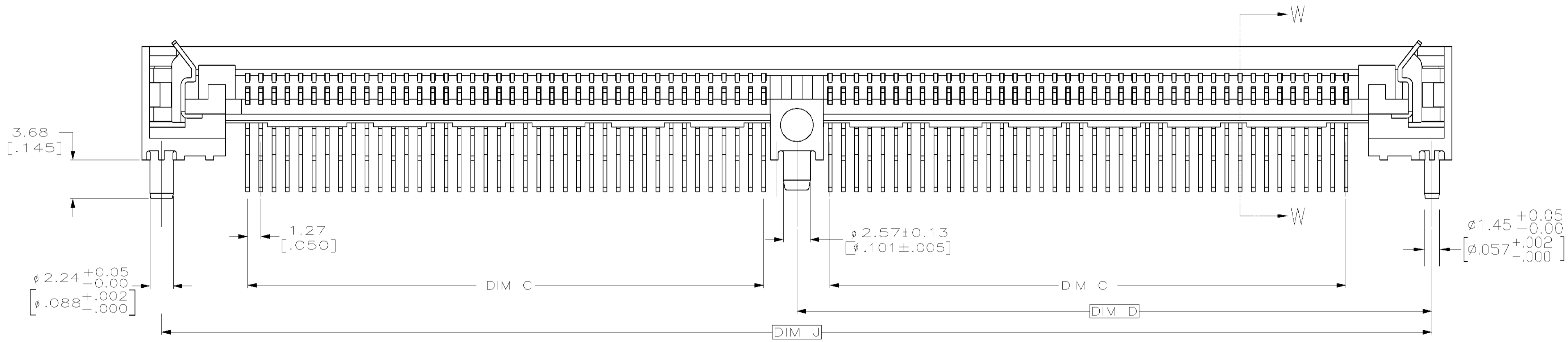
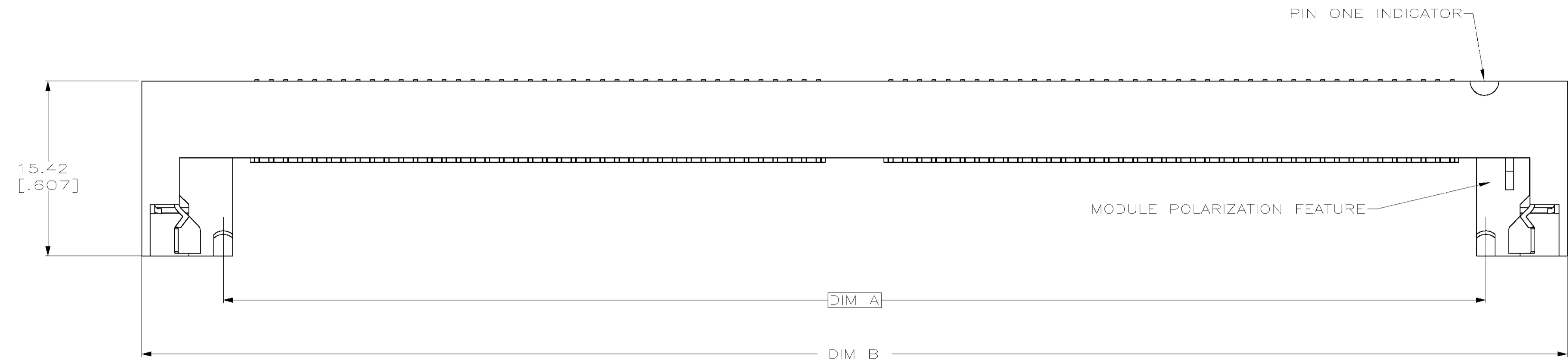

SECTION W-W
 SCALE 8:1

THIS DRAWING IS A CONTROLLED DOCUMENT.		DN T. BILLMAN 4-9-90	AMP Tyco Electronics Corporation Harrisburg, PA 17105	
DIMENSIONS: mm [INCHES]		CHK R. MILLER 4-9-90	NAME	
TOLERANCES UNLESS OTHERWISE SPECIFIED:		APVD R. SMITH 4-12-90	SIMM II RTANG 1.27[.050] ASSY 6.350[.250] HEIGHT	
0 PLC ± -	1 PLC ± -	PRODUCT SPEC	APPLICATION SPEC	RESTRICTED TO
2 PLC ± -	3 PLC ± 0.13[.005]	WEIGHT	SCALE 1:1	SHEET 1 OF 2
4 PLC ± -	ANGLES ± -	CUSTOMER DRAWING	REV L	
MATERIAL: HSG: GLASS REINF LCP (BLACK) CONTACT: PHOS. BRONZ	FINISH 2	A1 00779 © 382487		

LOC		DIST		P		F		ZONE		LTR		REVISIONS		
GP	00											DESCRIPTION	DATE	APPD
												SEE SHEET 1		

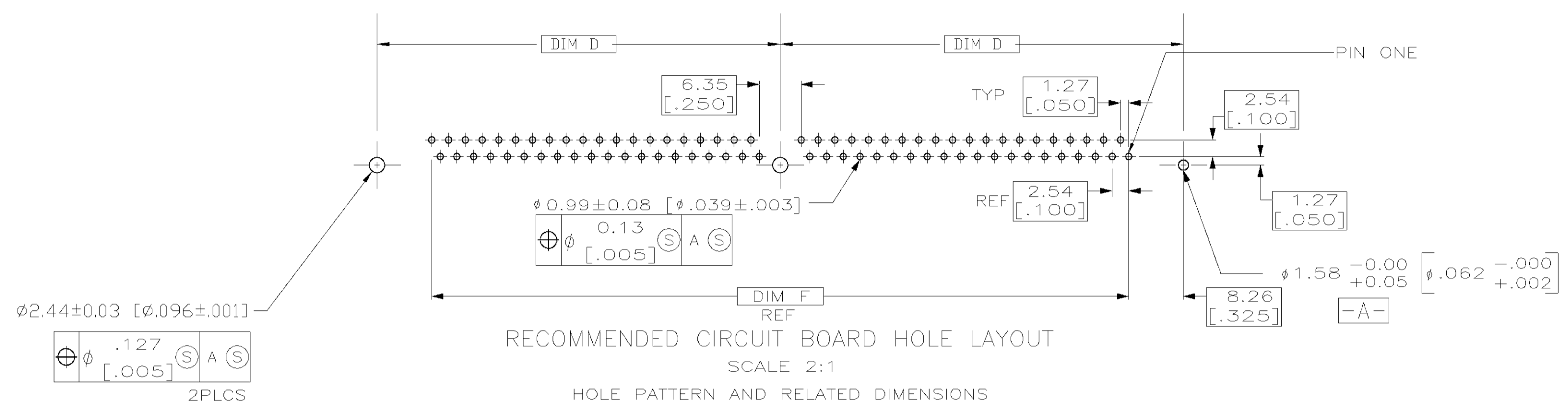

- FOR OPTIMUM PERFORMANCE, CONTACT PAD PLATING SHOULD BE SMOOTH AND FLAT. COPPER CONTACT PADS ARE TO BE OVERPLATED WITH .00127[.000050] MIN THK NICKEL FOLLOWED WITH .00101[.000040] MIN THK GOLD PLATING.
- CONTACT MATING AREA:
 0.00076 [.000030] MIN THICK GOLD.
 SOLDER TAIL: 0.00381 [.000150] MIN. THK TIN-LEAD.
 UNDERPLATE: 0.00127 [.000050] MIN. THK NICKEL OVER ENTIRE CONTACT.

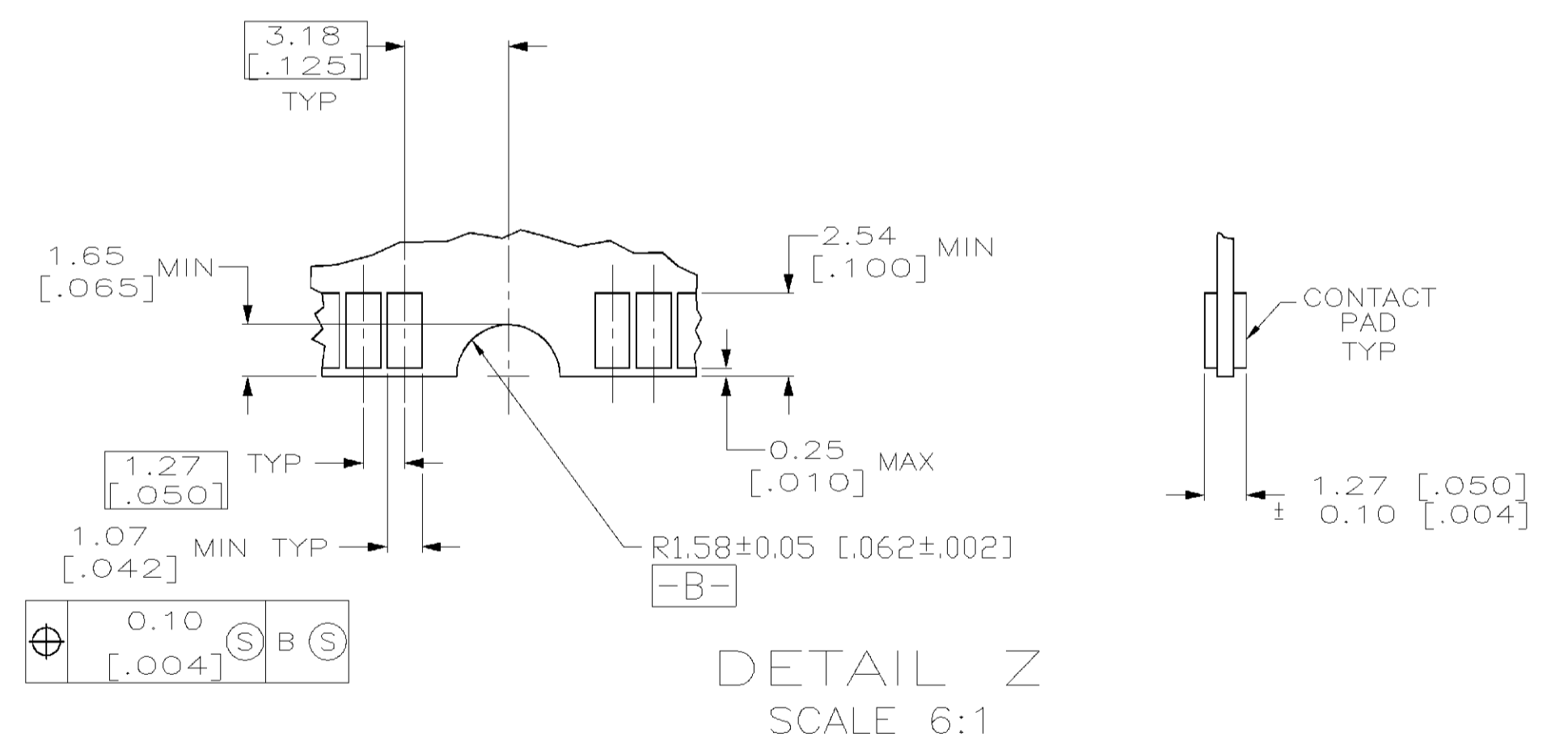
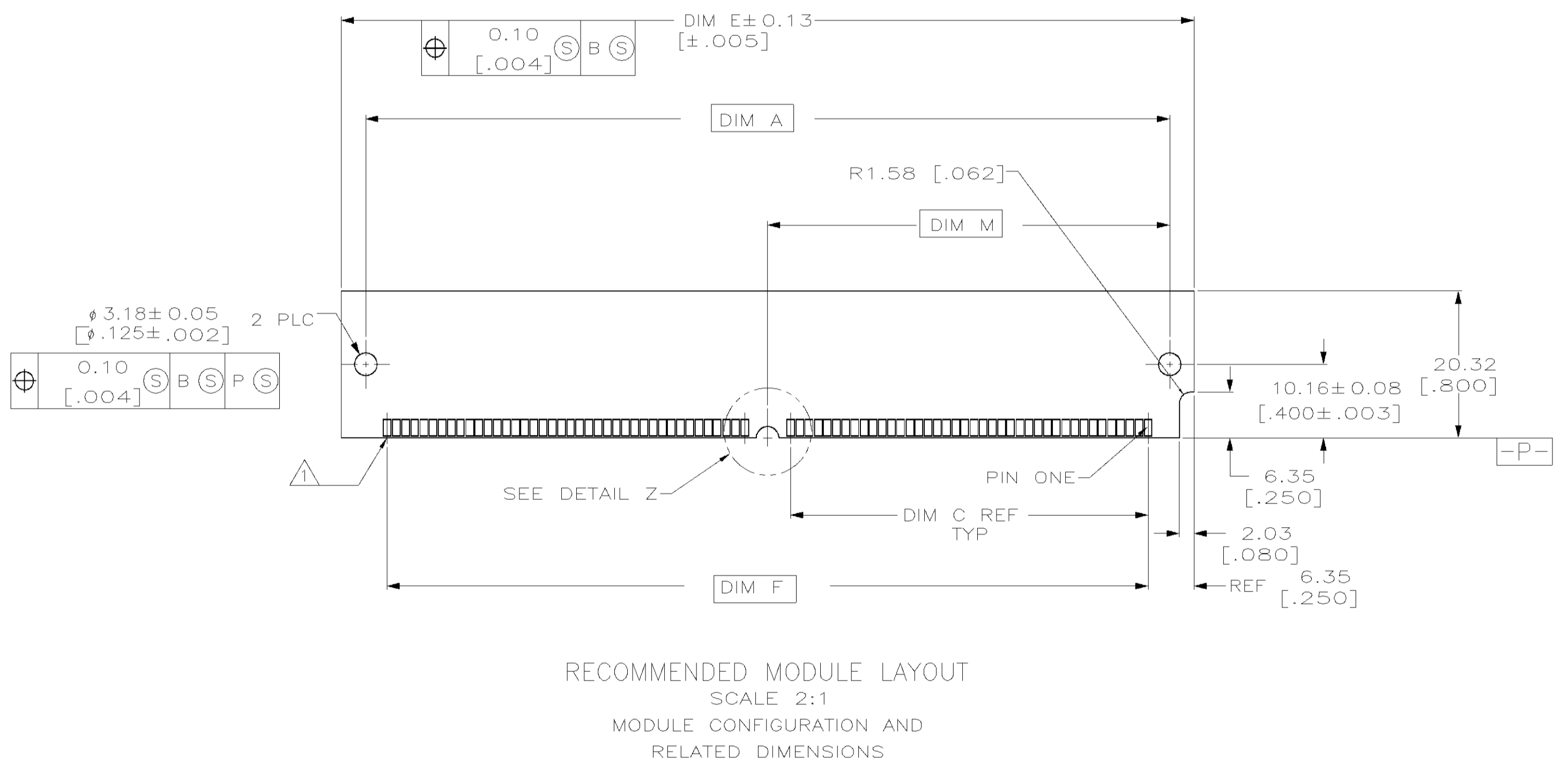

	58.22 [2.292]	127.00 [5.000]	110.49 [4.350]	123.19 [4.850]	63.50 [2.500]	52.07 [2.050]	130.81 [5.150]	116.43 [4.584]	84	8-382487-4
OBSOLETE	55.68 [2.192]	121.92 [4.800]	105.41 [4.150]	118.11 [4.650]	60.96 [2.400]	49.53 [1.950]	125.73 [4.950]	111.35 [4.384]	80	8-382487-0
	50.60 [1.992]	111.76 [4.400]	95.25 [3.750]	107.95 [4.250]	55.88 [2.200]	44.45 [1.750]	115.57 [4.550]	101.19 [3.984]	72	7-382487-2
	48.06 [1.892]	106.68 [4.200]	90.17 [3.550]	102.87 [4.050]	53.34 [2.100]	41.91 [1.650]	110.49 [4.350]	96.11 [3.784]	68	6-382487-8
OBSOLETE	45.52 [1.792]	101.60 [4.000]	85.09 [3.350]	97.79 [3.850]	50.80 [2.000]	39.37 [1.550]	105.41 [4.150]	91.03 [3.584]	64	6-382487-4
	30.28 [1.192]	71.12 [2.800]	54.61 [2.150]	67.31 [2.650]	35.56 [1.400]	24.13 [.950]	74.93 [2.950]	60.55 [2.384]	40	4-382487-0
	DIM M	DIM J	DIM F	DIM E	DIM D	DIM C	DIM B	DIM A	POSN	PART NO

DO NOT SCALE PRINT. UNLESS SPECIFIED DIMENSIONS IN mm [INCHES] TOLERANCES ON: 2 PLC DEC ± - 3 PLC DEC ± 0.13 [.005] ANGLES ± -	DR 4-9-90 T.BILLMAN CHK 4-9-90 R.MILLER APPD 4-12-90 R.SMITH APPD 4-12-90 R.SMITH PRODUCT SPEC - APPLICATION SPEC - WEIGHT -	AMP AMP Incorporated Harrisburg, PA 17105-3608 NAME SIMM II, RTANG, 1.27 [.050] ASSY, 6.35 [.250] HGT SIZE D CAGE CODE 00779 DRAWING NO 382487 SCALE 4:1 SHEET 2 OF 2
--	--	--